



SERVING THE FOOD INDUSTRY SINCE 1951

#32 Stainless Steel Meat Grinder 1.5HP

ITEM: 48888

MODEL: MG-CN-0032-E

Ideal for butcher shops, food stores & restaurants

Omcan's powerful grinders
are designed to handle large quantities
of meat with ease & speed



FEATURES

- Powerful motor can grind up to 720 - 750 lb. of meat per hour
- Durable construction with stainless steel knife, head ring, auger, and meat pan
- Permanently lubricated motor with improved grease formulation to reduce noise
- Heavy-duty handle for easy moving
- Long-lasting metal gears with roller bearings ensure smooth and reliable operation.
- Micro safety switch for meat tray
- Built-in circuit breaker
- Comes with 2 stainless steel cutting plates for coarse and fine grinding
- Includes 3 stuffing tubes

Telephone: 1-800-465-0234

Fax: (905) 607-0234

Email: sales@omcan.com

Website: www.omcan.com



Authorized Dealer



#32 Meat Grinder 1.5HP

ITEM: 48888



TECHNICAL DRAWING & DIMENSIONS

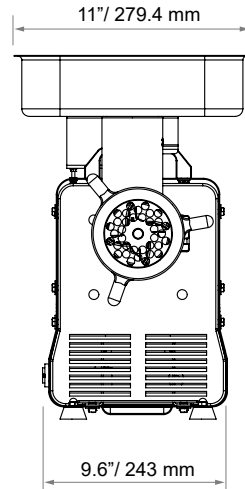
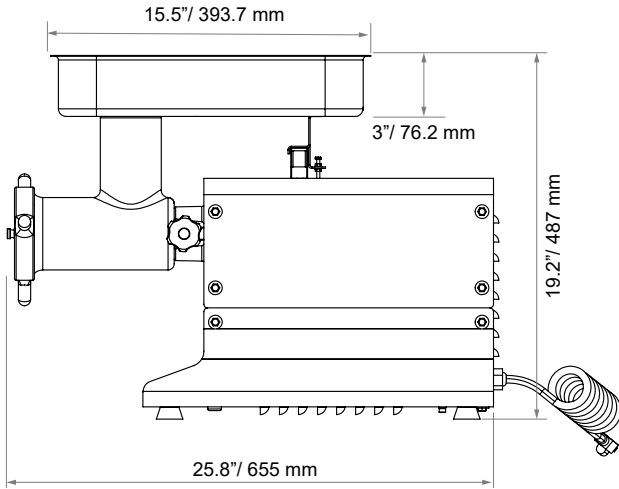

SPECIFICATIONS

Item Number	48888
Model	MG-CN-0032-E
Hub size	#32
Usage	Medium Duty
Power	1.5 HP/ 1,100 W
Electrical	120V / 60Hz / 1Ph
Transportation type	Gear-Driven
Capacity	720 - 750 lb. / 326.6 - 340 kg per hour
Includes	4.5 mm + 10 mm plates 3 stuffing tubes + 1 meat stomper
Outlet Speed	110 RPM or 150 RPM
Micro safety switch for meat tray	YES
Meat Tray Size	15.5" x 11" x 3" / 393.7 x 279.4 x 76.2 mm
Net Dimensions (DWH)	25.8" x 12.2" x 19.2" / 655 x 310 x 477 mm
Gross Dimensions (DWH)	26" x 16.6" x 16.8" / 660.4 x 421.6 x 426.7 mm
Net weight	65.7 lbs/ 30 kg
Gross weight	71.5 lbs/ 32.4 kg

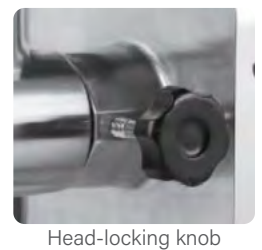

Improved auger design that speeds up meat grinding process and reduces jams and clogs



Large all-metal gear structure provides durability, roller bearing for smoother and quieter running



Larger-bite auger grabs more meat to improve production efficiency



Stainless steel accessories



Includes food-grade stuffing tube and meat stomper



Dust-proof switch

