



FOOD EQUIPMENT

SERVING THE FOOD INDUSTRY SINCE 1951

PIZZA SHAPING MACHINE

Item: 45356 | Model: BE-IT-0045



MAKE PIZZA DOUGHS FAST AND EASY!

This pizza shaping machine is ideal for forming pizza doughs. It can be easily used by non-specialised operators, and have a steel structure equipped with a ratio motor, cam, stop timer and plates. Ideal for restaurants and pizza shops.



WARRANTY
PARTS AND LABOR



Authorized Dealer

FOOD EQUIPMENT

PIZZA SHAPING MACHINE BE-IT-0045 | ITEM: 45356



TECHNICAL SPECIFICATIONS

ITEM NUMBER	45356
MODEL	BE-IT-0045
POWER	8.10 kW
DOUGH WEIGHT	551.15 - 1102.31 lbs. / 250 - 500 kg.
LOWER PLATE DIAMETER	17.7" / 450 mm
UPPER PLATE DIAMETER	17.7" / 450 mm
PLATES TEMPERATURE	130°C - 170°C / 266°F - 338°F
ELECTRICAL	230V / 60Hz / 1Ph
DIMENSIONS (LWH)	24.8" x 26.4" x 35" / 630 x 670 x 890 mm
PACKAGING DIMENSIONS	28.3" x 36.6" x 40.2" / 720 x 930 x 1020 mm
WEIGHT	280 lbs. / 127 kg.
PACKAGING WEIGHT	331 lbs. / 150 kg.

TECHNICAL DRAWING AND DIMENSIONS

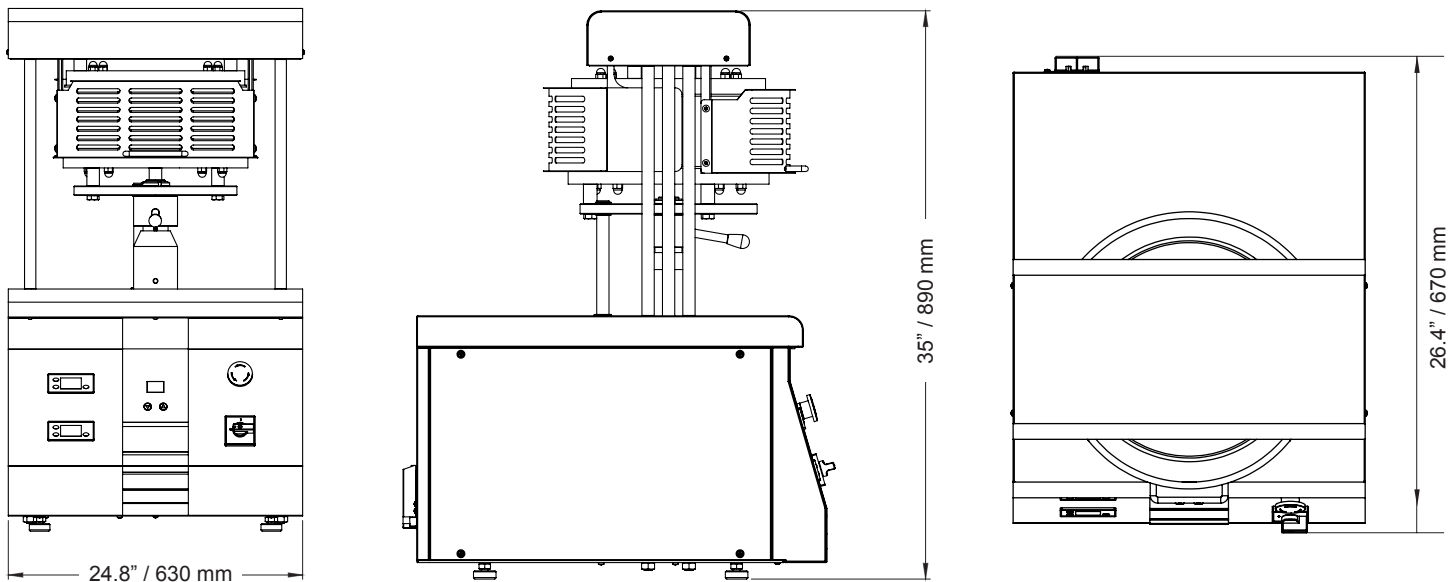

OMCAN INC.

Telephone: 1-800-465-0234

Fax: (905) 607-0234

Email: sales@omcan.com

Website: www.omcan.com



Follow us to keep up to date with the latest news and offers



2017.E.O.E

FOOD EQUIPMENT

PIZZA SHAPING MACHINE BE-IT-0045 | ITEM: 45356



PRODUCT DETAILS

- The plates, as they are made out of adhesive proof aluminum, have fast heating times that, together with a reduction in the set temperature from 150/170°C to 130°C due to a special surface treatment, permit significant energy savings; this treatment makes it easy to slide the pizza disk.
- The high quality of the dough is maintained due to the lower temperature.
- Due to their particular structure, disks of dough can be obtained with a traditional edge.
- The distance between the plates ranges is 115 mm.
- The pressing time (from 0.1 to 1.5 sec) and the temperature (150°C-170°C) vary depending on the dough temperature (recommended between 6°C and 20°C).
- The dough thickness can be easily adjusted by rotating the handle located under the lower plate.
- If the protective grid is removed, make sure to reassemble it correctly for proper machine operation, otherwise it may not restart.
- The grid can be removed to make it easier and quicker to clean the plates after they have cooled down.



WARRANTY

PARTS AND LABOR



OMCAN INC.

Telephone: 1-800-465-0234

Fax: (905) 607-0234

Email: sales@omcan.com

Website: www.omcan.com



Follow us to keep up to date with the latest news and offers



2017.E.O.E