



JUICE BAR SOLUTION

CENTER OF ALL YOUR FOOD SERVICE NEEDS

CENTRIFUGAL JUICER 100 Liters/Hr

Item #: 39494

Model: SANTOS #50



The Santos #50 is easy to use, silent and powerful, it is the ideal appliance for hotels, bars, restaurants, cafeterias, cocktail bars, institutions, hospitals, health food stores, juice bars and ice cream shops.

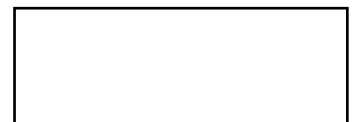

Authorized Dealer



JUICE BAR SOLUTION

CENTRIFUGAL JUICER 100 LITERS/ HR



Diagram

Safety: locking system. Electric cut off and motor braking when opening tyhe handle.

Filter basket: obtain a perfect filtration thanks to its very fine sieve (0.5mm/ 0.02" holes). Basket with 0.8mm holes available upon request.

Spout height: 200mm. Compatible glasses, jugs and blender jars.

A cleaning brush and maintenance set (1 shifter rubber + 3 seals) are delivered with the appliance.

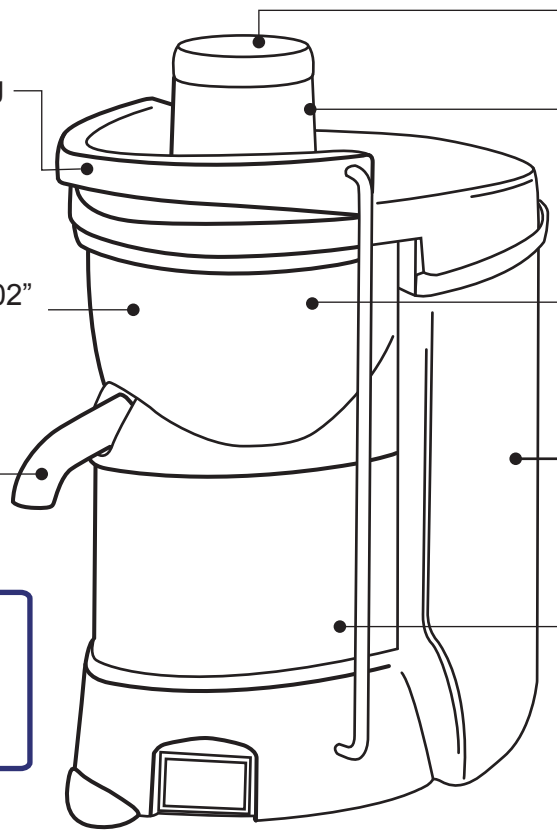

Pusher: low effort, constant flow, maximum yield.

Extra wide feeding chute: Ø 79.5mm (3"). No need to cut fruits or vegetables

Ezy-clean™ system: removable bowl, basket and cover (no tool needed).

Large capacity pulp container: 7.5l (2 gallons).

Powerful: Asynchronous motor, powerful (800W) and very silent.

- Removal centrifugal basket made of micro perforated stainless steel sheet
- Standard basket is provided with 0,5 mm diameter holes.
- Continuous juice production by centrifugal action and automatic pulp ejection.
- Height of the spout 8" (200 mm) allows for use of high glasses or containers.
- High output more than 1 liter/minute.
- Wide circular feeding hole (diameter 79 mm ;3") no need to cut fruits or vegetables (citrus fruits must be peeled).
- Stainless steel bowl and base.
- Easy to use, easy to clean.
- Patented locking-unlocking system with special lever.
- Motor braking when opening.

PRODUCT SPECIFICATIONS

ITEM NUMBER	39494
MODEL	Santos #50
PRODUCTION (PER HOUR)	100L/ 105.67 Qts
POWER	800 Watts
HP	1
RPM	3600
ELECTRICAL	120V/ 60Hz/ 1
CURRENT	7A
WEIGHT	14 kg / 31 lbs.
PACKAGING WEIGHT	16kg/ 35lbs.
DIMENSIONS	19" x 10" x 18"
PACKAGING DIMENSIONS	20" x 12" x 22"

OMCAN INC.

Telephone: 1-800-465-0234

Fax: (905) 607-0234

Email: sales@omcan.com

Website: www.omcan.com



Follow us to keep up to date with the latest news and offers



QUALITY, EXPERTISE, COMFORT

High quality juice

- **Perfect filtration:** very fine sieve offering a high quality juice
- **Maximum juice extraction:** excellent yield, dry pulp in the container.
- **Preservation of vitamins:** it extracts juice from fruits and vegetables without crushing or heating them
- **Creativity:** possibility to make any kind of juice, ex: ginger, beetroot, cucumber, pineapple, melon, grapes.

Expertise

- **Exclusive patents:** exclusive extra wide feeding chute, Ezy-clean™ system, instant friction breaking system.
- **Professional motor:** powerful and extremely silent (Santos know-how).
- **High output juice extractor:** adapted to intensive use (ex: juice bars).
- **Sturdy appliance:** mostly made of aluminum and stainless steel.

Simplicity and comfort

- **Silence:** you can serenely make juice in front of your costumers.
- **Space-saving product:** it fits everywhere thanks to its low overall dimensions.
- **Extra wide feeding chute:** you can put entire fruits and vegetables (time-savings)
- **Continuos juice production:** automatic pulp ejection.
- **Ezy-clean™ system:** removable bowl, basket and cover (no tool needed). Easy cleaning.
- **Large basket:** more juice, less cleaning.



Safety, Standards, Hygiene

In accordance with the following regulations:

- Machinery directive 2006/42/EC
- Electromagnetic compatibility 2004/108EC
- Electrical equipment designed for use within certain voltage limits "low voltage" 2006/95/EC
- RoHs directive 2002/95/EC
- Regulation 1935/2004/EC (contact with food)

Harmonized European standards:

- EN ISO 12100 - 1 and 2: 2004
- EN 60204 - 1: 2006
- EN 12547 + A 1: 2009 juice extractors
- EN 60335 - 2- 64: 2004: Commercial electric kitchen machines
- CE (European standards), UL (USA) and cUL (Canada), NSF (USA), KC (Korea)
- GS (Germany) checked by the LNE (National Test Laboratory)

Thermal safety:

- Motor protected by internal thermal detector and overload protector.

Electric safety:

- On/off switch detects overloading and no voltage.
- All mechanical parts are ground (earth) connected.
- Appliances are 100% tested after assembly.

Acoustic safety:

Silent asynchronous motor.

Mechanical safety:

A friction brake emmedately stops the basket when opening the handle.

Hygiene:

All removable parts can be put in a dishwasher or easily cleaned with hot soapy water (NSF approved).

OMCAN INC.

Telephone: 1-800-465-0234

Fax: (905) 607-0234

Email: sales@omcan.com

Website: www.omcan.com



Follow us to keep up to date with the latest news and offers

