



KITCHEN EQUIPMENT

SERVING THE FOOD INDUSTRY SINCE 1951

No. 22 ECONOMICAL STAINLESS STEEL MEAT GRINDER

ITEM: 23626 MODEL: MG-CN-0022-S



MINCE DIFFERENT TYPES OF MEAT QUICKLY AND EFFICIENTLY

Ideal for home use, as well as small butcher shops and delis. Stainless steel construction. Comes with 3 spouts (15mm, 20mm, 23mm), and 2 machine plates (6mm, 8mm). Comes with a maximum horsepower of 1.50 HP and a nominal power of 0.91 HP.



WARRANTY
PARTS AND LABOR

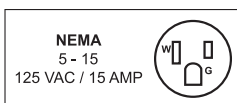

Authorized Dealer



Features:

- Ideal for butcher shops and delis
- Constructed of stainless steel body, housing, and head
- 3 spouts (15mm, 20mm and 23mm)
- 2 machine plates (6mm and 8mm)

TECHNICAL DRAWING AND DIMENSIONS

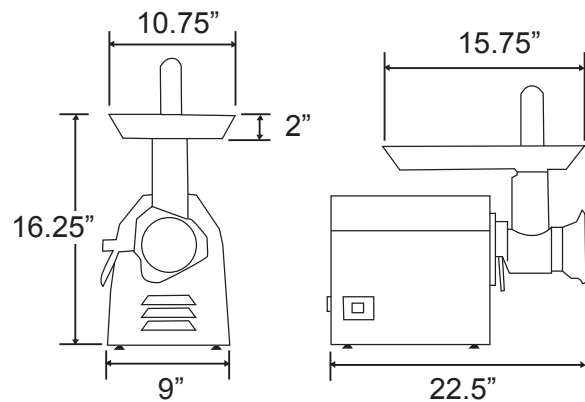

TECHNICAL SPECIFICATIONS

ITEM NUMBER	23626
MODEL	MG-CN-0022-S
POWER	1.50 HP / 1.12 kW
THROAT OPENING	Approximately 2" / 50.8 mm
CAPACITY	485 lbs. /hr.
ELECTRICAL	110V / 60Hz / 1Ph
WEIGHT	80 lbs. / 36.3 kg.
PACKAGING WEIGHT	96 lbs. / 43.5 kg.
DIMENSIONS (DWH)	22.5" x 9" x 16.25" / 571.5 x 228.6 x 412.75 mm
PACKAGING DIMENSIONS	24" x 14" x 19" / 609.6 x 355.6 x 482.6 mm

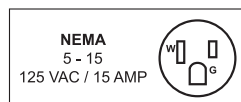

OMCAN INC.

Telephone: 1-800-465-0234
 Fax: (905) 607-0234
 Email: sales@omcan.com
 Website: www.omcan.com



Follow us to keep up to date with the latest news and offers

