



SERVING THE FOOD INDUSTRY SINCE 1951

#12 STAINLESS STEEL MEAT GRINDER WITH REVERSE SWITCH

Item: 21720 | Model: MG-CN-0012-E



**MAKE FRESHLY GROUND MEAT
FAST AND EASY**



WARRANTY
PARTS AND LABOR



NEMA
5 - 15 R
125 VAC / 15 AMP
RECEPTACLE



Authorized Dealer

KITCHEN EQUIPMENT

#12 STAINLESS STEEL MEAT GRINDER WITH REVERSE SWITCH



FEATURES

- Made of attractive polished aluminium
- Equipped with a reverse switch
- Comes with a stainless steel pan, stomper, three additional spouts (14mm, 20mm, 22mm) and an extra machine plate (8mm and 4.8 mm)
- Ideal for restaurants or small butcher operations

TECHNICAL SPECIFICATIONS

ITEM NUMBER	21720
MODEL	MG-CN-0012-E
POWER	1.0 HP / 0.75 kW
RPM	200
THROAT OPENING	2" / 50.8 mm approx.
ELECTRICAL	110V / 60Hz / 1Ph
WEIGHT	55 lbs. / 25 kg.
PACKAGING WEIGHT	62.5 lbs. / 28.41 kg.
DIMENSIONS (DWH)	18" x 10.75" x 18.25" 457.2 x 273.05 x 463.55 mm
PACKAGING DIMENSIONS	21.5" x 14" x 17" 546.1 x 355.6 x 431.8 mm

TECHNICAL DRAWINGS AND DIMENSIONS

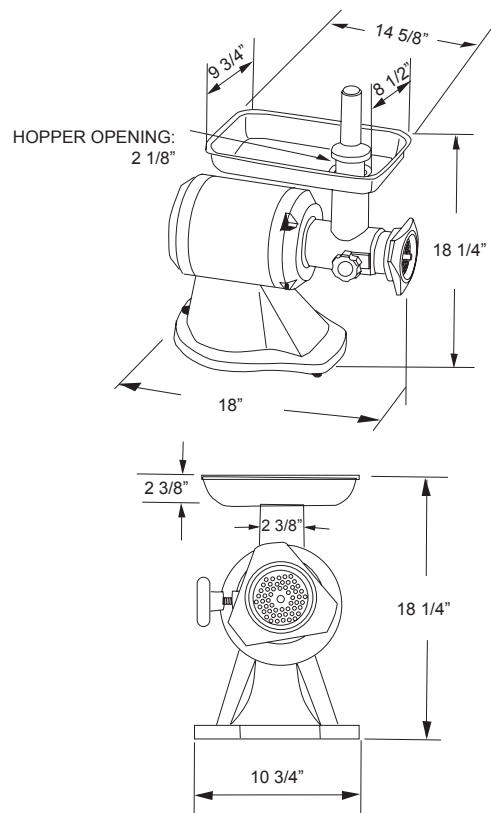

WARRANTY
PARTS AND LABOR

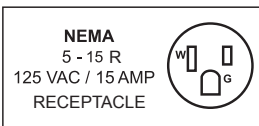

OMCAN INC.

Telephone: 1-800-465-0234

Fax: (905) 607-0234

Email: sales@omcan.com

Website: www.omcan.com



Follow us to keep up to date with the latest news and offers



2016.E.O.E