



SERVING THE FOOD INDUSTRY SINCE 1951

3-HP FLOOR BAND SAW

Item: 10272 Model: BS-VE-3200-S | Item: 18943 Model: BS-VE-3200-T



**CUT SLABS OF MEAT QUICKLY,
EASILY, AND PRECISELY**

Fabricated in steel with electrostatic oven paint, complete with an aluminum head. Its stainless steel table has a four-wheel base that slides on rails. Equipped with adjustable legs. Easy to disassemble for quick cleaning and maintenance.



WARRANTY
PARTS AND LABOR



Authorized Dealer

FOOD EQUIPMENT

3-HP FLOOR BAND SAW BS-VE-3200-S / BS-VE-3200-T



TECHNICAL SPECIFICATIONS

ITEM NUMBER	10272	18943
MODEL	BS-VE-3200-S	BS-VE-3200-T
POWER	3 HP / 2.24 kW	
BLADE LENGTH	126" / 3200 mm	
BLADE SAW DIMENSIONS	0.78" x 12.60" / 20 x 320 mm	
CUTTING CAPACITY	15" x 18" / 381 x 457 mm	
POWER	3 HP / 2.24 kW	
ELECTRICAL	220V / 60 Hz / 1 Ph	220V / 60 Hz / 3 Ph
AMPS	11A	9A
WEIGHT	374 lbs. / 170 kg.	
PACKAGING WEIGHT	415 lbs. / 188 kg.	
PACKAGING DIMENSIONS	40" x 54" x 96" / 1016 x 1372 x 2438 mm	

TECHNICAL DRAWING AND DIMENSIONS

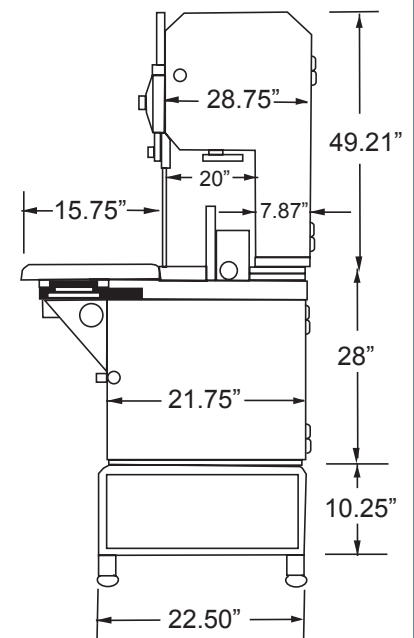
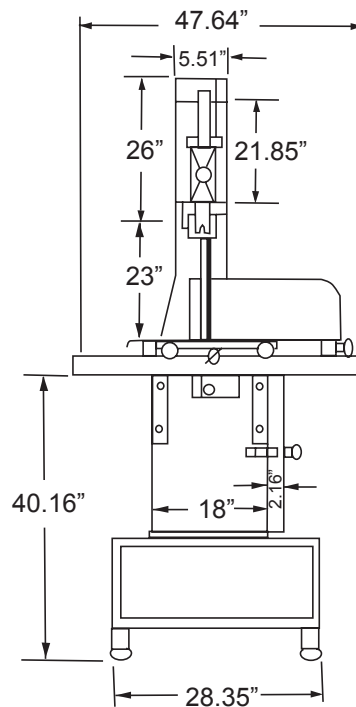

Features

- Stainless steel finish with electrostatic oven paint
- Perfect for butcher shops and groceries
- Easy accessibility for operation, disassembly, and cleaning



WARRANTY
PARTS AND LABOR



OMCAN INC.

Telephone: 1-800-465-0234

Fax: (905) 607-0234

Email: sales@omcan.com

Website: www.omcan.com



Follow us to keep up to date with the latest news and offers



2015.E.O.E