

# NOM-36-HTS

## GRAB 'N GO HEATED OPEN MERCHANDISERS

Ideal for restaurants, cafés, convenience stores and supermarkets



## FEATURES



Pull-down night curtain



Price tag channels

Temperature of each shelf is independently controlled



Black brushed stainless steel exterior

Warm-toned LED lighting on the top of unit and under each shelf



Digital temperature control w/ separate light switch

4 heavy duty casters and 2 front legs



# SPECIFICATIONS

Capacity (Cubic Feet)	6.04
Capacity (Litres)	171 L
Exterior Unit Dimensions (in)	35.4" (w) x 33.5" (d) x 53.5" (h)
Interior Dimensions	32.25" (w) x 23" (d) x 28" (h)
Net / Gross Weight (lb)	276 / 419
Night Curtain	Yes
Swivel Casters	4 casters
Front Support Leg	1
Shelves	2 + base
Shelf Dimensions	32.65" (w) x 11.08" (d) (top) 32.65" (w) x 14.8" (d) (middle) + (base) 32.65" (w) x 22" (d)
Shelf Capacity (lb)	80
Temperature	65-71°C
Input Power	2849 - 3792 W
Voltage	208-240V/60H/1PH
Amperage	13.7A - 15.8A
Plug Type	Not supplied - designed for Nema 6-30p

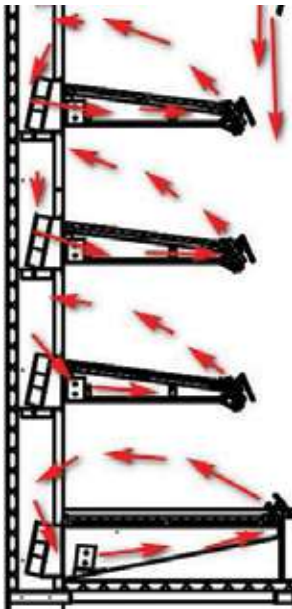

**AIR CIRCULATION:**  
Hot air circulates around each shelf surface keeping products warm. These units are designed to hold pre-cooked foods at 65°C to 71°C (149°F to 160°F)

FRONT VIEW

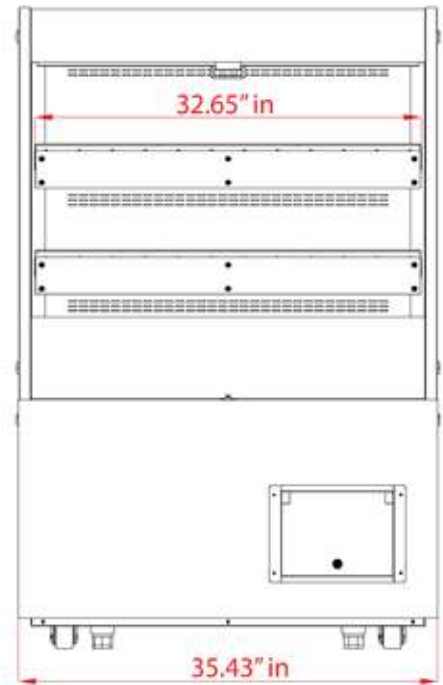

SIDE & INTERIOR VIEW

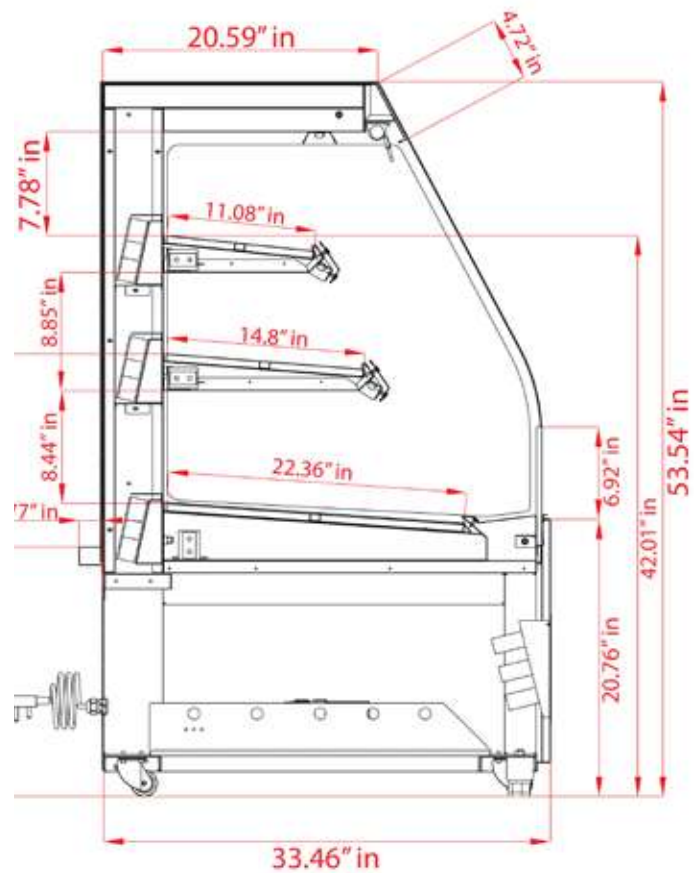

CUSTOMER SUPPORT



We're on social media!  
1.800.567.3620



[www.newairrefrigeration.ca](http://www.newairrefrigeration.ca)

MORE PRODUCTS!



Design and specifications can change without prior notice for product improvement